

Exploring micro-grids for building energy applications

Solving the alternative energy management problem

Michael R. Lavelle, P.E.
Lavelle Energy LLC

Micro-Grid Applications

Leveraging XMPP short messaging

Overview

Micro-grids are in the early stages of being introduced to building energy management applications. The opportunity to combine different energy sources, such as combined heat and power (CHP) generators, solar cells, batteries, and even supercaps, is the first step to a successful alternative energy source for building power. Micro-grid management networks are designed to synchronize multiple energy sources with the Grid, and with building loads. Tying building loads to the micro-grid is a separate challenge, one that can double the effectiveness of a micro-grids during peak energy usage periods. This paper describes a methodology to connect multiple sources to the Grid, and buildings to the sources using XMPP short messaging protocol. It resolves both source and load management issues using widely applied Open Source software.

Power Connections

Micro-grid building power connections can be viewed as a collection of equipment wired in parallel with the primary Grid collection. The diagram in Figure 1 explains power flow but must be extended for micro-grid power management.

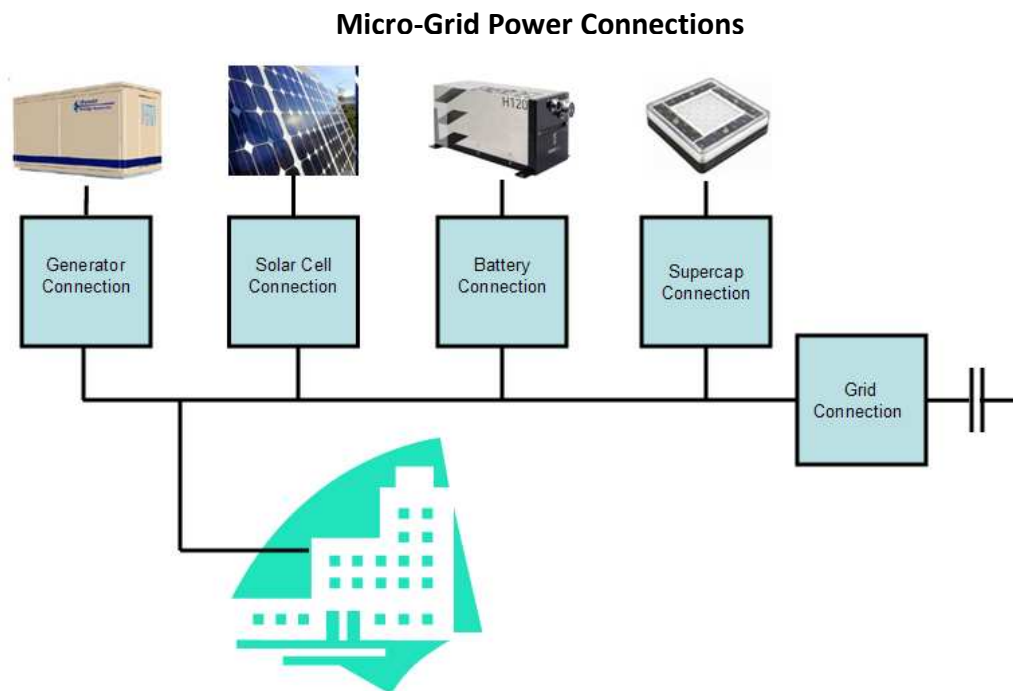

Figure 1.

Management Connections

Linking energy sources and loads changes the connection diagram. Sources must connect to loads and loads must respond to instructions from sources. Building energy usage and demand becomes a monitored component of the micro-grid the same as other energy sources.

Micro-Grid Management Connections

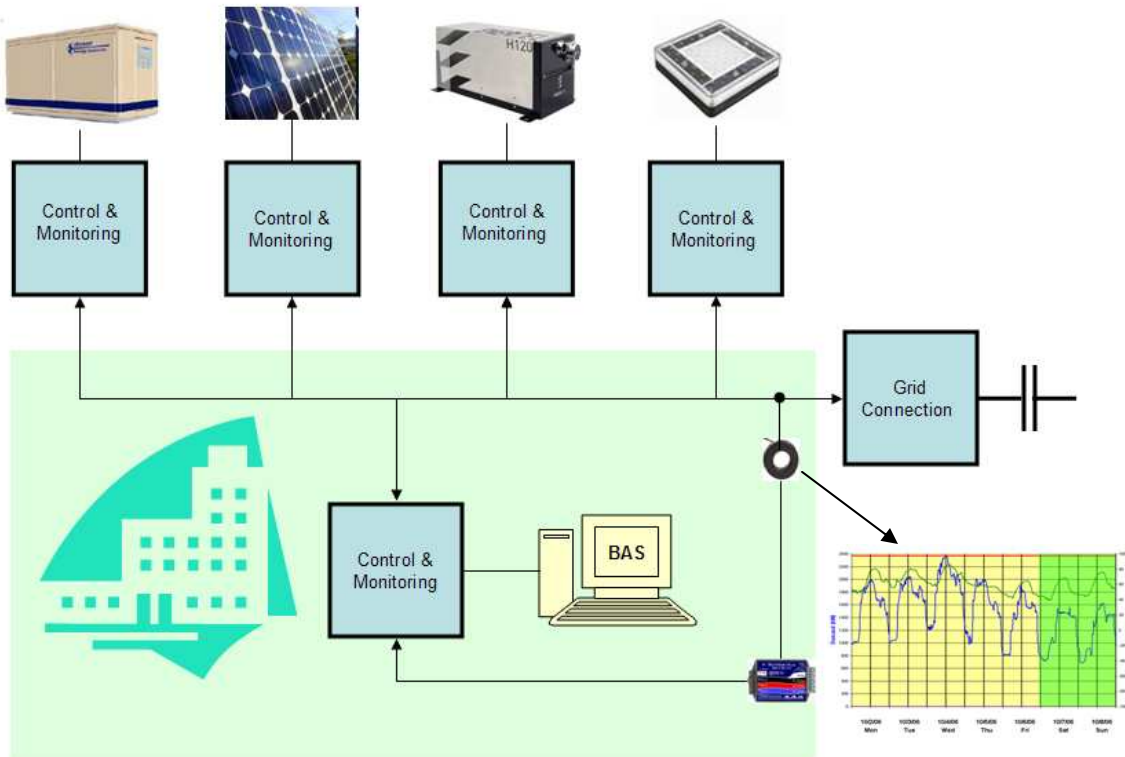

Figure 2.

Building interval data adds to understanding how energy is used throughout the day and week. Intervals can range from seconds to minutes to help allocate energy between alternative sources and loads on the micro-grid. Building automation systems, when available, can be used to expedite control and monitoring of HVAC environmental equipment. Conceptually the process is simple. In practice there are a number of considerations.

Moving Data

Sources and loads need to communicate with one another and do so quickly. This is an opportunity for short messaging. Building automation protocols, like BACnet, work within their own real-time communications control loops, but are not designed to handle fast movement of short data packets for micro-grid performance. Nor is this an opportunity to use http and web servers. Http, by design, provides for querying a web server for data and does not provide a built-in two-way connection. Instead, this is a better opportunity for short messaging protocol XMPP, widely used by Twitter, Google Talk, Facebook, and other large scale applications. The ability to leverage XMPP for micro-grid operations offers a number of additional opportunities through the XMPP extensions including: Service Discovery (disco) to publish available node properties and features, Publish-Subscribe to replace repetitive polling, Bidirectional-streams Over Synchronous HTTP (BOSH) for Internet connectivity and off-site support, Message Archiving for local node data logging, Serverless Messaging for communicating over local and wide-area networks

using zero-configuration networking for endpoint discovery, Out-of-band Stream Data for transporting large binary files, and more than 150 other extensions.

XMPP Connections

This paper describes an XMPP implementation called PowerMan where XMPP servers and clients are embedded into a single application running the Linux OS. Individual equipment connections require specialized control and monitoring code shown in Figure 3 as GenSet, Solar, Battery, and Supercap applications. Energy sources and loads are grouped together as an XMPP domain, where data is automatically shared between nodes.

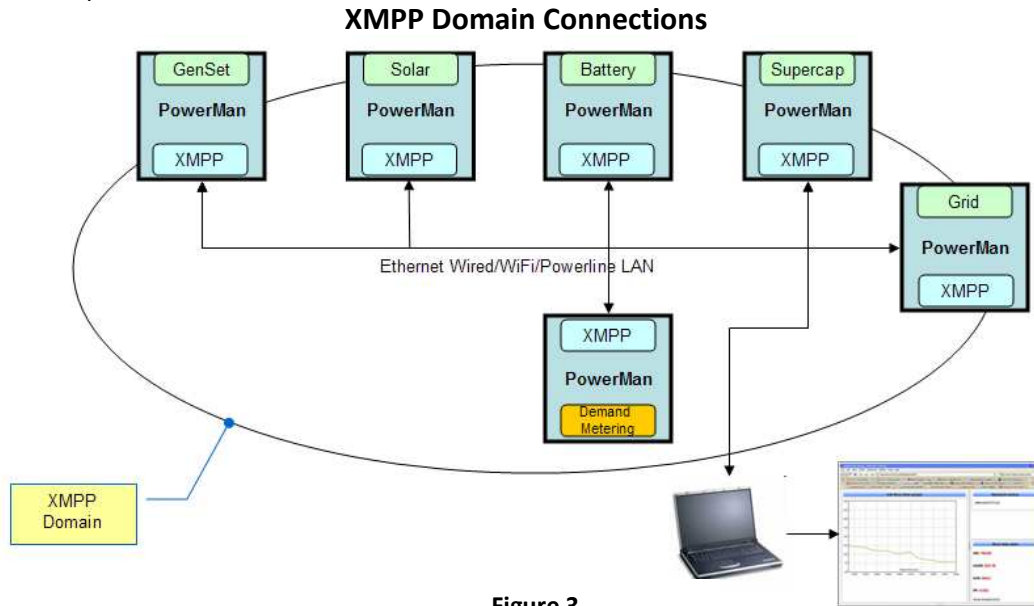

Figure 3.

XMPP domains simplify equipment connections by providing a single entity for all nodes to interact with during operation. PowerMan uses the eJabberd¹ implementation of XMPP server which runs on Erlang², a non-stop programming language that uses Linux sockets for low-level, fast communications.

The use of XMPP also provides the ability to minimize network traffic using the Publish-Subscribe (pub-sub) extension. PowerMan connections from each node can subscribe to data from any other node, which is only sent upon a change in value. The use of pub-sub extends to the man-machine interface where process variables update simultaneously on connected browser applications. Browser code is written in Javascript. Plug-ins are not needed. One to a thousand users can subscribe to real-time data with overall update times ranging from 200ms to 1000ms. Figure 4 shows how connections work equally effectively through a firewall to outside XMPP clients using the BOSH extension. Domains can extend from inside a building to outside hosted Internet-connected XMPP servers. A single XMPP server can operate multiple domains.

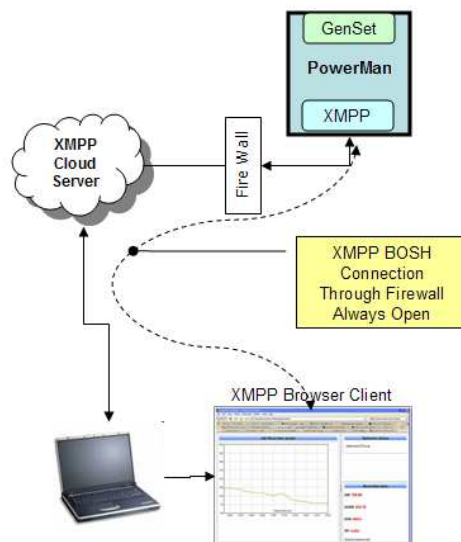

Figure 4.

¹ <http://www.ejabberd.im/>

² [http://en.wikipedia.org/wiki/Erlang_\(programming_language\)](http://en.wikipedia.org/wiki/Erlang_(programming_language))

Extended Domains

Most micro-grid installations involve alternative generation equipment mounted separately on or near a building. In these installations it's helpful to split the energy source network from the building management network. In Figure 5 below XMPP uses a connection through a Cloud server to link an

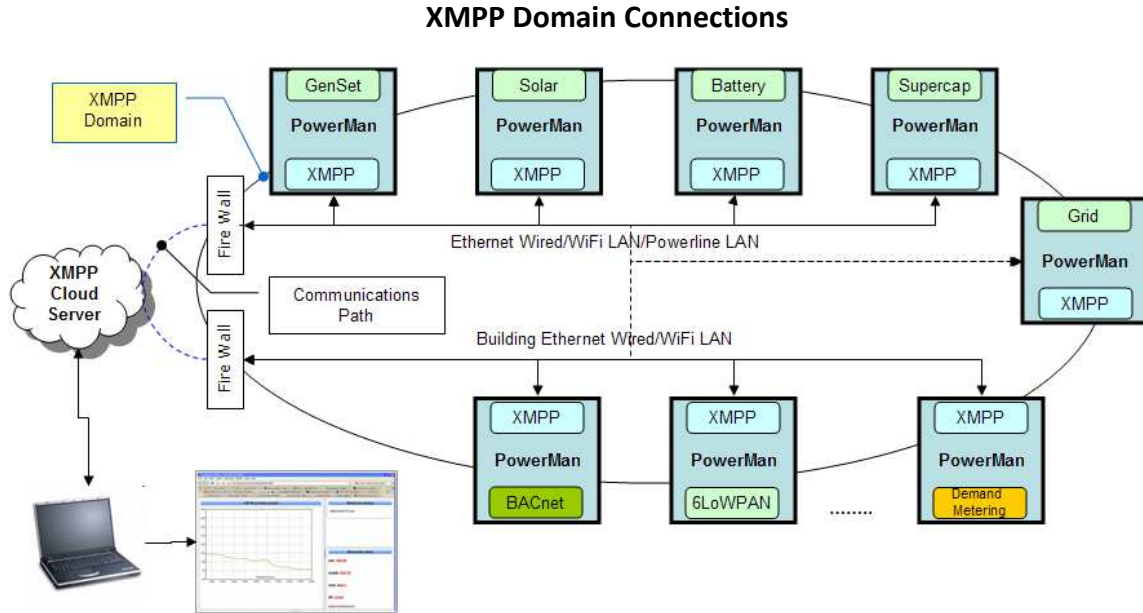

Figure 5.

external energy source management network with an internal building load management network. The Grid connection can be optionally monitored through either network LAN. The monitoring connection can run through the Cloud server whenever necessary. Users can also connect laptops at any point on either LAN and manage all micro-grid activity. The actual browser graphic is generated by an individual XMPP server attached to a particular energy source or load. Service Discovery automatically detects properties of each node. It follows that any number of buildings can be attached to and managed by similar Internet connections for wide-area aggregation of Grid-connected buildings.

Data Communications

Data movement between XMPP servers is handled automatically as part of the XMPP domain. Joining the domain automatically establishes the connections.

Inter-node XMPP Data Communications

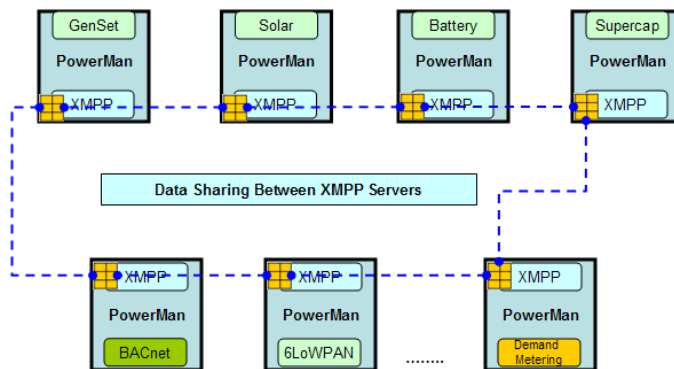
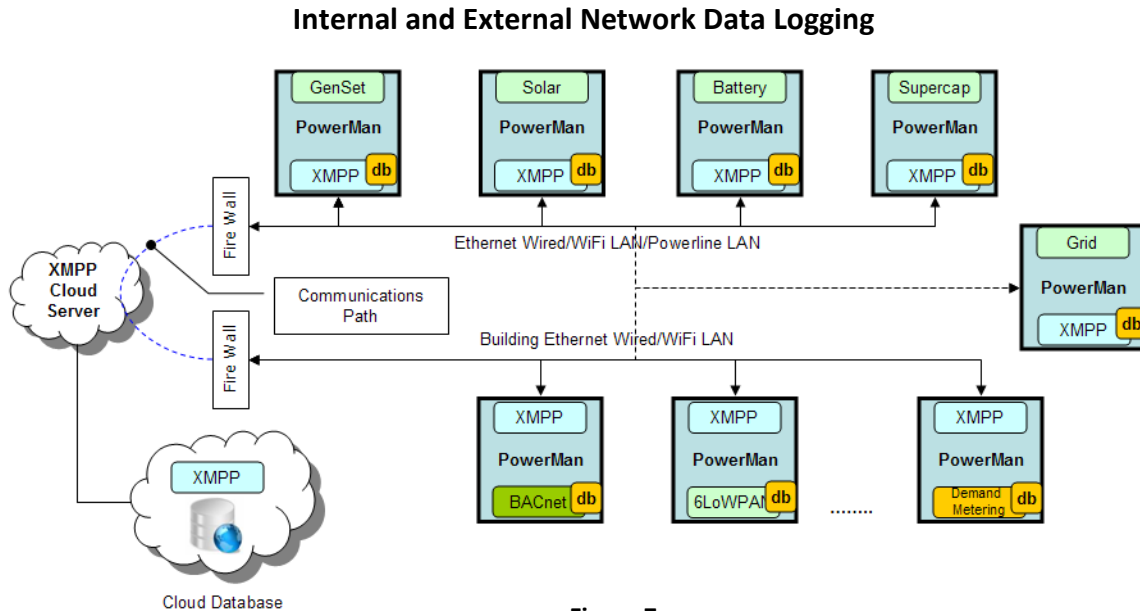

Figure 6.

Data Logging

Data logging is both local and global. Each XMPP server provides local data storage for immediate analysis and evaluation. This allows for fast, sub-second, data collecting and computations as required to synchronize energy sources. Subsets of this data, based on numerical or statistical computational methods, can be passed to a global Cloud database over the Internet as shown in Figure 7.



Using subsets of data reduces data traffic to the Cloud database. In situations where the Internet connection is temporarily unavailable, XMPP provides for continued local data collecting until the connection is restored, when data automatically updates. Local data storage is handled by the Erlang built-in Mnesia³ database.

PowerMan Functionality

PowerMan is available on a wide range of hardware. Synchronization requires additional Power Measurement Units (PMU) connected to PowerMan via a USB port. PMUs run on CAN bus or another suitable bus such as USB. In any case, fast communications is needed to manage the synchronization process. High speed synchronization functions run on PMU devices. PowerMan operates at layer two in functionality where the results of PMU computations are passed to PowerMan for network source and load management (see Figure 10).

Building automation system connections with PowerMan use the appropriate communications protocol. The preferred connection is Ethernet but serial connections are also supported. PowerMan also supports Zigbee⁴ and 6LoWPAN⁵ wireless devices. Wireless communications simplifies physical connections to loads like HVAC equipment and lighting or plug loads. Multi-hop mesh networks expedite in-building communications.



³ <http://en.wikipedia.org/wiki/Mnesia>

⁴ <http://en.wikipedia.org/wiki/Zigbee>

⁵ <http://en.wikipedia.org/wiki/6lowpan>

Combined Energy Sources

By using XMPP connectivity through and across the Internet, it is possible to link building-installed energy sources, such as generators, to external energy sources. Coordination between sources is handled by XMPP domain data communications as shown in Figure 8.

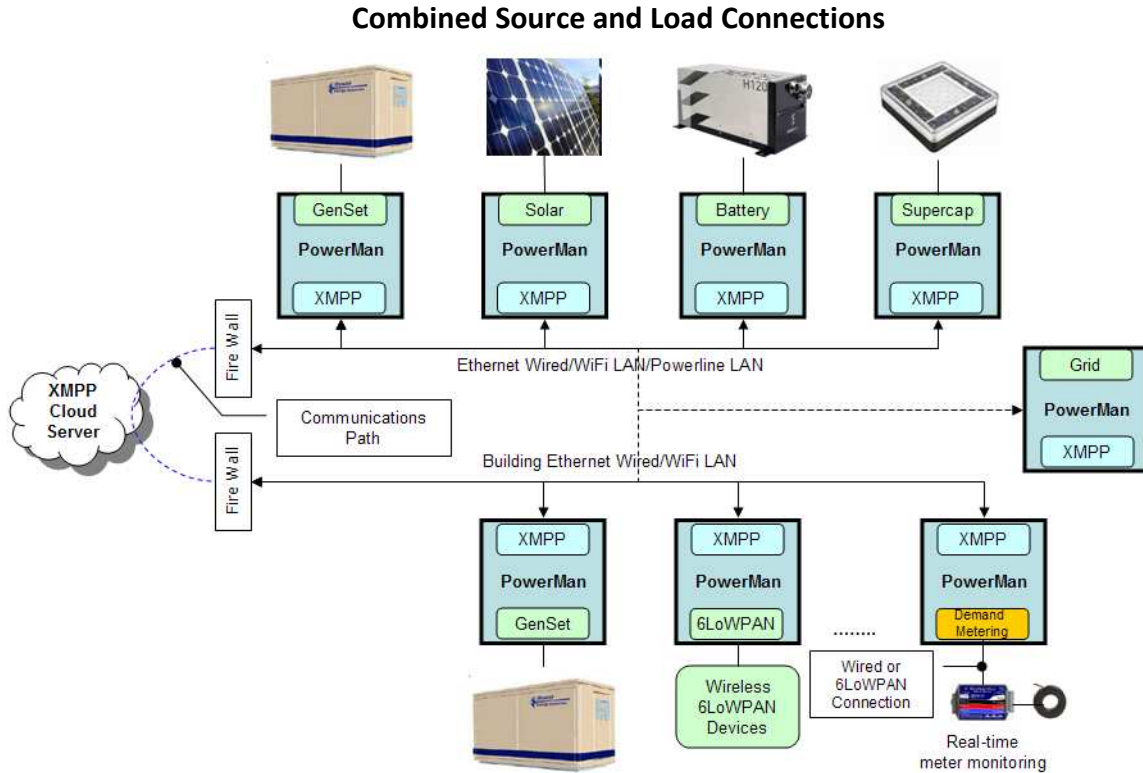

Figure 8.

Security

Communication security is provided by the Transport Layer Security protocol, XTLS, which provides communications privacy, and enables XMPP applications to communicate in a way that is designed to prevent eavesdropping, tampering, and forgery of XMPP stanzas. XTLS is based on Transport Layer Security⁶ (TLS) and provides equivalent security guarantees. The protocol sends standard TLS handshake and application data encoded as Base64.

TLS is the most widely implemented protocol for securing network traffic. In addition to applications in the email infrastructure, the World Wide Web (HTTP Over TLS; see [RFC 2818 \[6\]](#)), and datagram transport for multimedia session negotiation (DTLS; see [RFC 4347 \[7\]](#)), TLS is used in XMPP to secure TCP connections from client to server and from server to server, as specified in [XMPP Core \[8\]](#)

The basic idea behind XTLS is that two XMPP entities negotiate an encrypted "tunnel" between themselves over XMPP. The tunnel is negotiated using standard TLS handshake data, contained in XMPP stanzas and encapsulated as Base64-encoded payloads of a data element qualified by a dedicated namespace. The entities can then exchange TLS-encrypted XMPP stanzas over that tunnel.

⁶ TLS - <http://xmpp.org/extensions/inbox/xtls.html>

Physical Connections

Real world network data management connections are shown below in Figure 9. PowerMan appliances can be connected by Ethernet cable or WiFi to in-building networks. Individual equipment control is available through dedicated I/O or specialized communication protocols.

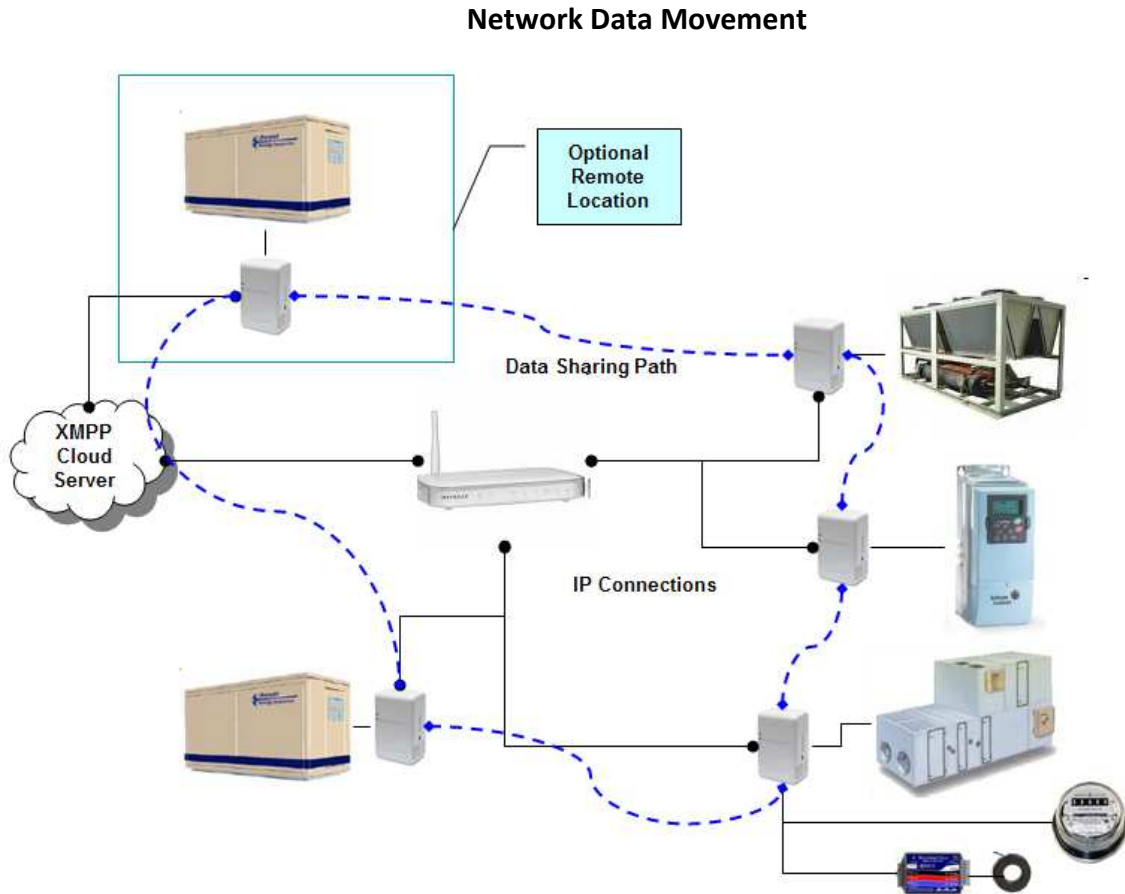

Figure 9.

Domain Specific Language

Building a set of control management rules is simplified through the use of domain specific language (DSL) built into PowerMan: Building Energy Management Language (BEML). This language connects equipment real-time variables to operating functions designed to quickly implement custom installations. Users can write custom low-level functions when necessary but most applications will use the provided high-level functions for most micro-grid and building energy management activity.

Micro-grid Source and Load Management

PowerMan operates just above the real-time functions of the PMU. Immediate Grid and power connection management resides in the PMU. PowerMan uses socket connections with the PMU code to read and write load and functional information within the BEML code. BEML code runs as an Erlang application. XMPP client connections to BEML applications use built-in Erlang socket connections. The Ejabberd XMPP server implementation includes a standard http web server for delivering user output to a browser. Any number of users can subscribe to XMPP server web pages. Real-time updates are provided only as data actually changes using pub-sub. Connections between browser applications, like the one in Figure 10, work over standard http sockets.

Visual Management

Building load management uses the same communication infrastructure but provides energy applications that directly control input and output devices, or control building automation systems through an appropriate protocol converter.

Real-time building information can also be delivered to graphical floor plan or equipment layouts by an XMPP client. In Figure 11, a building floor plan has real-time variables superimposed on the graphic. Users can switch to various plan views through a menu selection within the application.

Software Layers

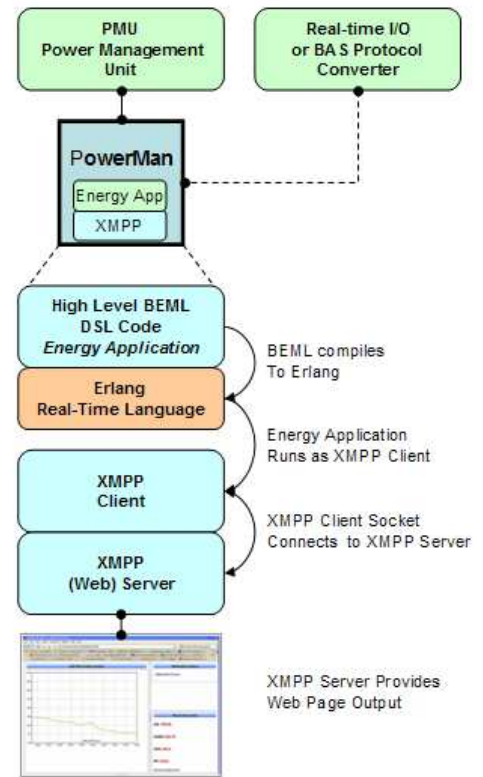

Figure 10.

The ability to visualize building operations, combined with real-time graphical data, provides useful insight for operating micro-grids. Real-time data can be viewed from any or all XMPP servers, and combined into a single display screen.

Summary

Micro-grids are an effective method for distributing power within and between buildings. Adding building demand control significantly improves the effectiveness of a micro-grid working within the larger Grid service. Coordinating energy sources and loads offers the best opportunity for leveraging limited resources. XMPP short messaging provides the type of communication connection that simplifies local and wide-area energy management.

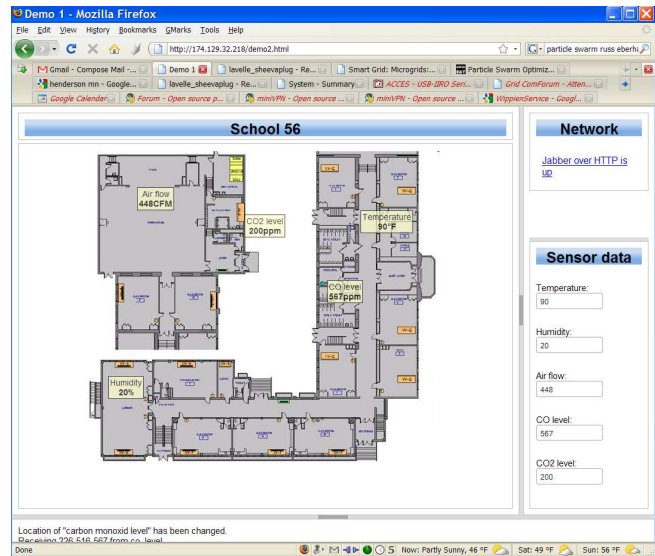

Figure 11.